

LRT SERIES

ROUGH TERRAIN SCISSOR LIFTS



Performance

Platform Height – Elevated

RT3394	10.06 m
RT4394	13.11 m
RT5394	16.2 m

Capacity with Dual Extensions

RT3394	905 kg
RT4394	565 kg
RT5394	680 kg

Capacity on Platform Extension

	225 kg
--	--------

Lift/Lower Time

RT3394	35/37 sec.
RT4394	45/47 sec.
RT5394	59/55 sec.

Maximum Drive Height

RT3394/RT4394	Full Height
RT5394	9.75 m

Weight with Dual Extension

RT3394	6,250 kg
RT4394	6,800 kg
RT5394	8,100 kg

Drive Speed – Lowered

	5.6 km/h
--	----------

Drive Speed – Raised

	0.8 km/h
--	----------

Gradeability

RT3394/RT4394	45%
RT5394	40%

Turning Radius (inside)

RT3394/RT4394	2.71 m
RT5394	2.72 m

Turning Radius (outside)

RT3394/RT4394	5.93 m
RT5394	5.92 m



Standard Specifications

Engine

Diesel Engine	Kubota D1305 T4i 21.7 kW
Fuel Tank Capacity	83.3 L

Tyres

- Standard
- RT3394/RT4394/RT5394 12 x 16.5 Foam Filled, Non-Marking

Hydraulic System

Capacity	121.42 L
----------	----------

Standard Features

- 4-Wheel Drive
- Automatic Transmission
- 3-Speed Drive Select
- Proportional Drive/Lift Up/Lift Down
- Oscillating Axle
- Leveling Jacks (outriggers)
- Dual Extension Deck
- Flashing Amber Beacon
- Self-Closing, Self-Locking Entry Gates
- Adjustable, Removable Platform Control Station
- Fold-Down Handrails
- Horn
- Tilt Light and Alarm

Accessories & Options

- AC Outlet to Platform, Including ELCB
- Wheel Chocks
- Squawker/White Noise Motion Alarm
- Platform Worklights
- Pipe Rack Accessory
- 5.5k VA Generator
- Flood Lights
- 12.7 mm Air Line to Platform
- Fire Extinguisher
- Battery Isolator

LRT SERIES

ROUGH TERRAIN SCISSOR LIFTS



Dimensions

All dimensions are approximate.

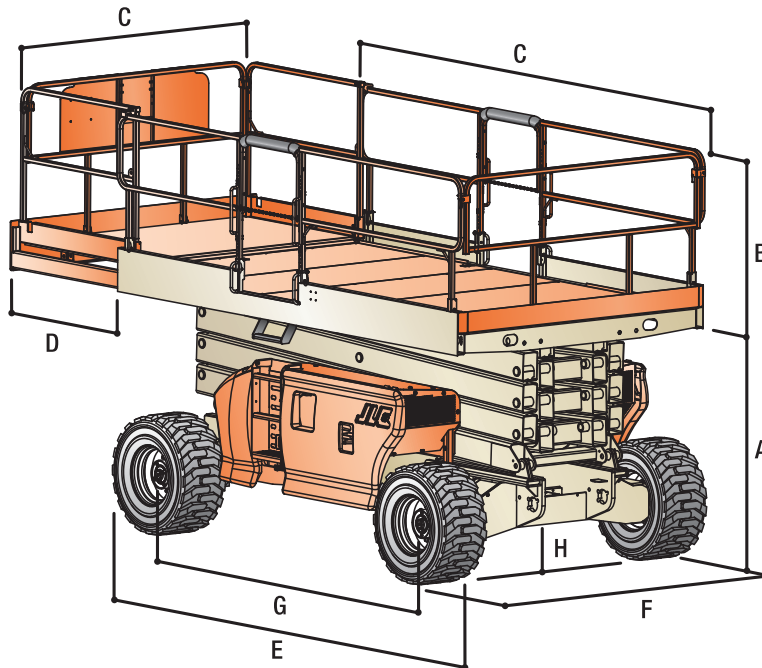

Platform Height — Elevated

RT3394	10.06 m
RT4394	13.11 m
RT5394	16.2 m

A. Platform Height — Lowered

RT3394	1.61 m
RT4394	1.84 m
RT5394	2.13 m

B. Platform Railing Height

RT3394/RT4394	1.1 m
RT5394	0.94 m

C. Platform Size

RT3394/RT4394	2 x 3.92 m
RT5394	1.87 x 3.96 m

D. Platform Extension

1.22 m

E. Overall Length

RT3394/RT4394	4.88 m
RT5394	5.18 m

F. Overall Width

RT3394/RT4394	2.36 m
RT5394	2.31 m

G. Wheelbase

2.97 m

H. Ground Clearance

RT3394/RT4394	34.5 cm
RT5394	30 cm

The JLG "1 & 5" Warranty

JLG Industries, Inc. backs its products with its exclusive "1 & 5" Warranty. We provide coverage on all products for one (1) full year and cover all specified major structural components for five (5) years. Due to continuous product improvements, we reserve the right to make specification and/or equipment changes without prior notification. This machine meets or exceeds AS/NZS 1418.10 2011 as originally manufactured for intended applications.

R042221



JLG Industries (Australia)

358 Park Road
Regents Park, NSW 2143
Telephone 02 8718 6300
Fax 02 8718 6377

www.jlg.com.au

An Oshkosh Corporation Company